

TORQUE CONVERTER

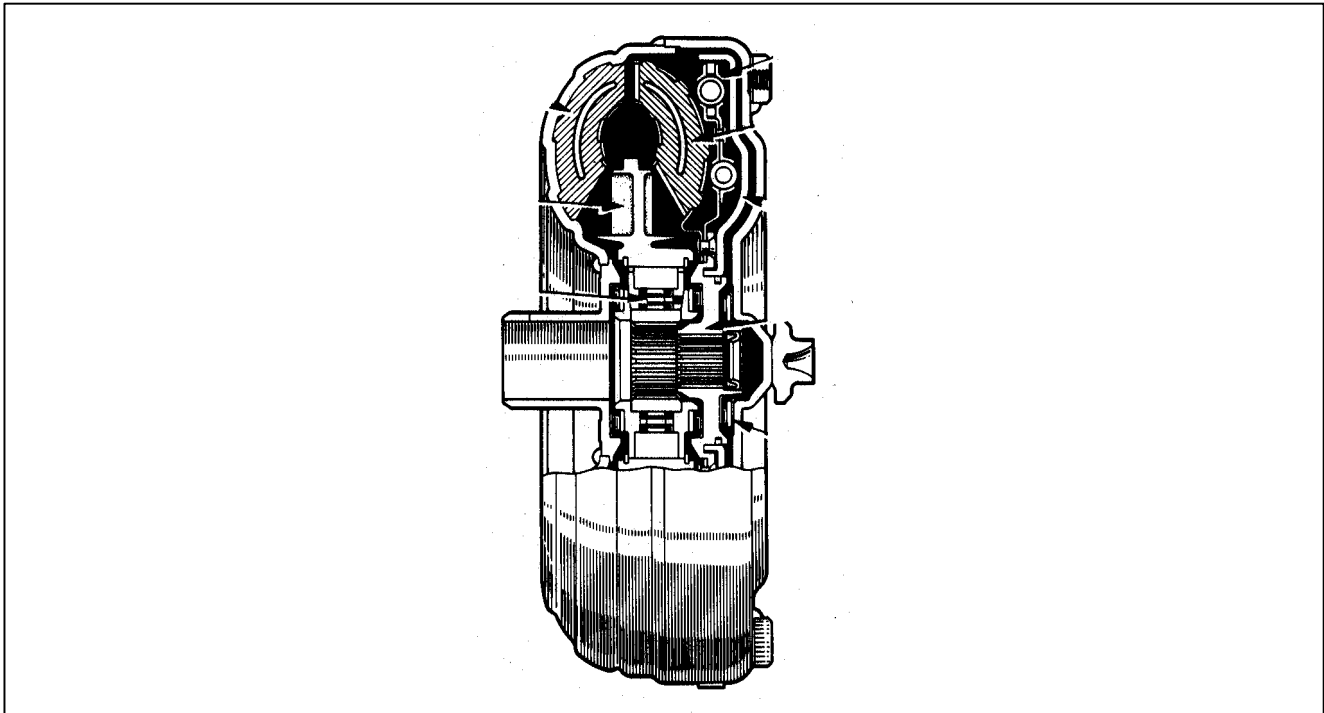

Lesson Objectives

1. Describe the function of the torque converter.
2. Identify the three major components of the torque converter that contribute to the multiplication of torque.
- 3 Describe the operation of each major torque converter component.
4. Describe the operation of the lock-up mechanism of the torque converter.
5. Distinguish between vortex flow and rotary flow in a torque converter.
6. Identify two symptoms of a failed stator one-way clutch.
7. Determine when replacement or service of the converter is appropriate.

The torque converter is mounted on the input side of the transmission gear train and connected to a drive plate. The drive plate, or flex plate as it is sometimes referred to, is used to connect the converter to the crankshaft flywheel flange of the engine. The ring gear, which the starter motor engages to turn the engine, is attached to the drive plate.

Torque Converter

Transmits engine torque to the transmission input shaft.

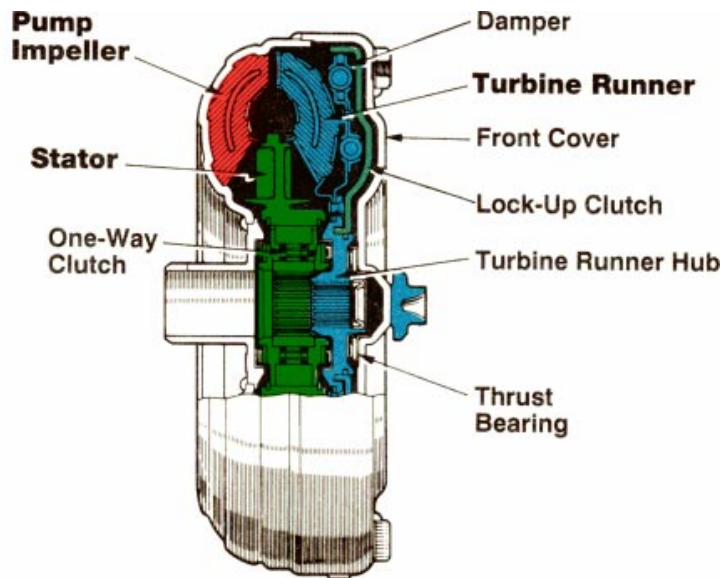

Role of the torque converter:

- Multiplies torque generated by the engine.
- Serves as an automatic clutch which transmits engine torque to the transmission.
- Absorbs torsional vibration of the engine and drivetrain.
- Smooths out engine rotation.
- Drives the oil pump of the hydraulic control system.

The torque converter is filled with automatic transmission fluid, and transmits the engine torque to the transmission. The torque converter can either multiply the torque generated by the engine or function as a fluid coupling.

The torque converter also serves as the engine flywheel to smooth out engine rotation as its inertia helps to maintain crankshaft rotation between piston power pulses. It tends to absorb torsion vibration from the engine and drivetrain through the fluid medium since there is no direct mechanical connection through the converter.

In addition, the rear hub of the torque converter body drives the transmission oil pump, providing a volume of fluid to the hydraulic system. The pump turns any time the engine rotates, which is an

important consideration when a vehicle is towed. If the vehicle is towed with the drive wheels on the ground and the engine is not running, the axles drive the transmission output shaft and intermediate shaft on bearings that receive no lubrication. There is a great potential for damage if the vehicle is towed for a long distance or at greater than low speeds.

Torque Converter Components

The torque converter's three major components are; the pump impeller, turbine runner and the stator. The pump impeller is frequently referred to as simply the impeller and the turbine runner is referred to as the turbine.

Pump Impeller

The impeller is integrated with the torque converter case, and many curved vanes that are radially mounted inside. A guide ring is installed on the inner edges of the vanes to provide a path for smooth fluid flow.

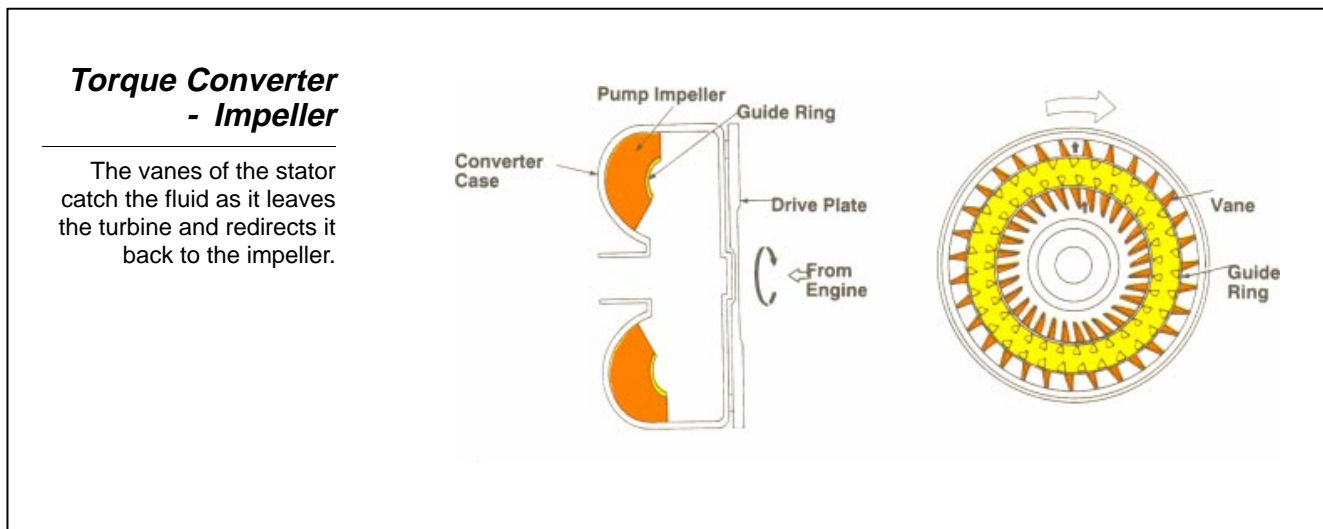

When the impeller is driven by the engine crankshaft, the fluid in the impeller rotates with it. When the impeller speed increases, centrifugal force causes the fluid to flow outward toward the turbine.

Turbine Runner The turbine is located inside the converter case but is not connected to it. The input shaft of the transmission is attached by splines to the turbine hub when the converter is mounted to the transmission. Many cupped vanes are attached to the turbine. The curvature of the vanes is opposite from that of the impeller vanes. Therefore when the fluid is thrust from the impeller, it is caught in the cupped vanes of the turbine and torque is transferred to the transmission input shaft, turning it in the same direction as the engine crankshaft.

Torque Converter - Turbine

Fluid is caught in the cupped vanes of the turbine and torque is transferred to the input shaft.

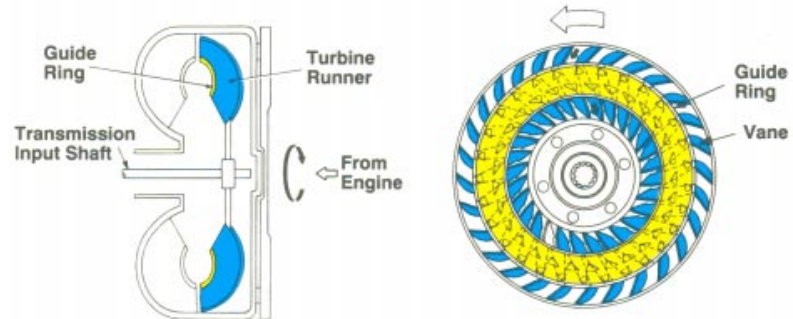

Fluid Coupling Before moving on to the next component of the torque converter we need to examine the fluid coupling whose components we have just described. When automatic transmissions first came on the scene in the late 1930s, the only components were the impeller and the turbine. This provided a means of transferring torque from the engine to the transmission and also allowed the vehicle to be stopped in gear while the engine runs at idle. However, those early fluid couplings had one thing in common; acceleration was poor. The engine would labor until the vehicle picked up speed. The problem occurred because the vanes on the impeller and turbine are curved in the opposite direction to one another. Fluid coming off of the turbine is thrust against the impeller in a direction opposite to engine rotation.

Notice the illustration of the torque converter stator on the following page; the arrow drawn with the dashed lines represents the path of fluid if the stator were not there, such as in a fluid coupling. Not only is engine horsepower consumed to pump the fluid initially, but now it also has to overcome the force of the fluid coming from the turbine. The stator was introduced to the design to overcome the counterproductive force of fluid coming from the turbine opposing engine rotation. It not only overcomes the problem but also has the added benefit of increasing torque to the impeller.

Stator The stator is located between the impeller and the turbine. It is mounted on the stator reaction shaft which is fixed to the transmission case. The vanes of the stator catch the fluid as it leaves the turbine runner and redirects it so that it strikes the back of the vanes of the impeller, giving the impeller an added boost or torque. The benefit of this added torque can be as great as 30% to 50%.

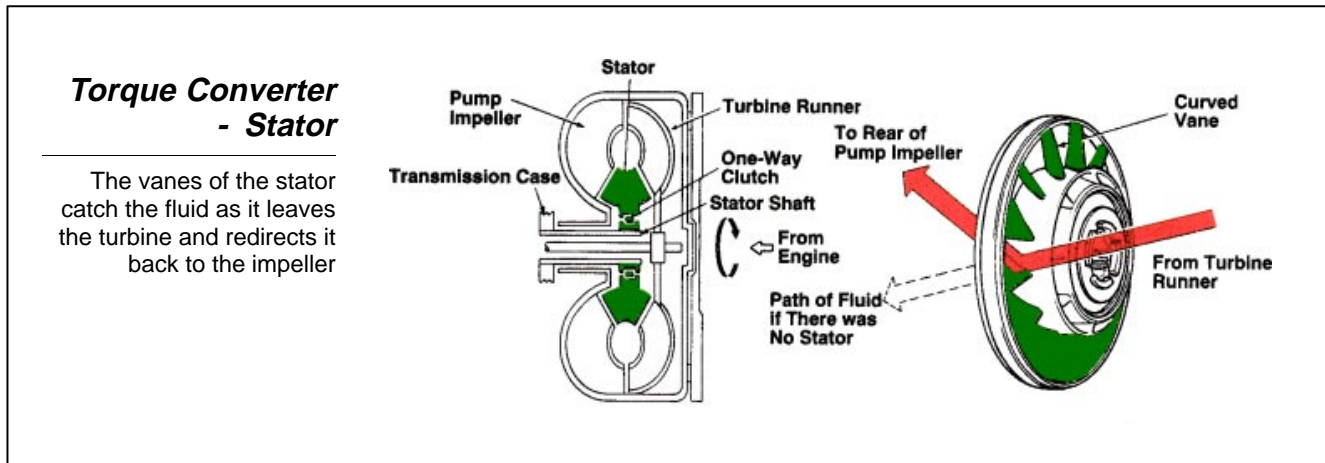

The one-way clutch allows the stator to rotate in the same direction as the engine crankshaft. However, if the stator attempts to rotate in the opposite direction, the one-way clutch locks the stator to prevent it from rotating. Therefore the stator is rotated or locked depending on the direction from which the fluid strikes against the vanes.

Converter Operation

Now that we've looked at the parts which make up the torque converter, let's look at the phenomenon of fluid flow within the torque converter. When the impeller is driven by the engine crankshaft, the fluid in the impeller rotates in the same direction. When the impeller speed increases, centrifugal force causes the fluid to flow outward from the center of the impeller and flows along the vane surfaces of the impeller. As the impeller speed rises further, the fluid is forced out away from the impeller toward the turbine. The fluid strikes the vanes of the turbine causing the turbine to begin rotating in the same direction as the impeller.

After the fluid dissipates its energy against the vanes of the turbine, it flows inward along the vanes of the turbine. When it reaches the interior of the turbine, the turbine's curved inner surface directs the fluid at the vanes of the stator, and the cycle begins again.

Stator Operation

The stator one-way clutch locks the stator counterclockwise and freewheels clockwise.

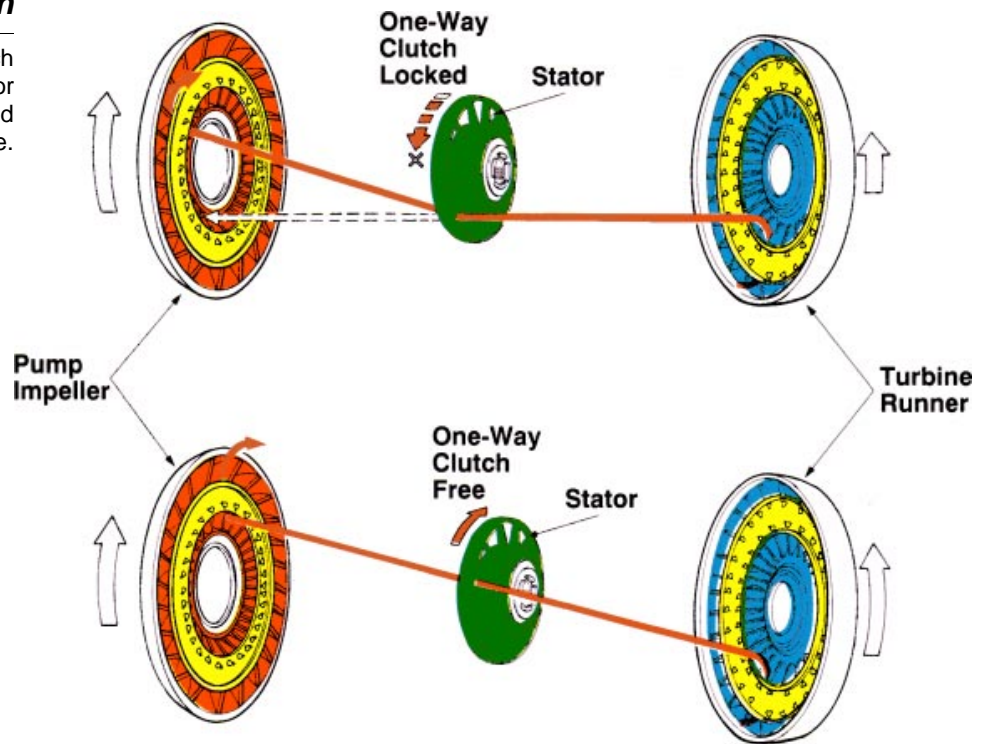

Converter Fluid Flow

We've already mentioned that the impeller causes the fluid to flow to the turbine and transfers torque through the fluid medium and then passes the stator and back to the impeller. But there are times when this flow is quicker and more powerful than at other times, and there are times when this flow is almost nonexistent.

Vortex and Rotary Flow

There are two types of fluid flow within the converter: one is vortex flow, and the other is rotary flow. In the illustration of the converter fluid flow below, vortex flow is a spiraling flow which continues as long as there is a difference in speed between the impeller and the turbine. Rotary flow is fluid flow which circulates with the converter body rotation.

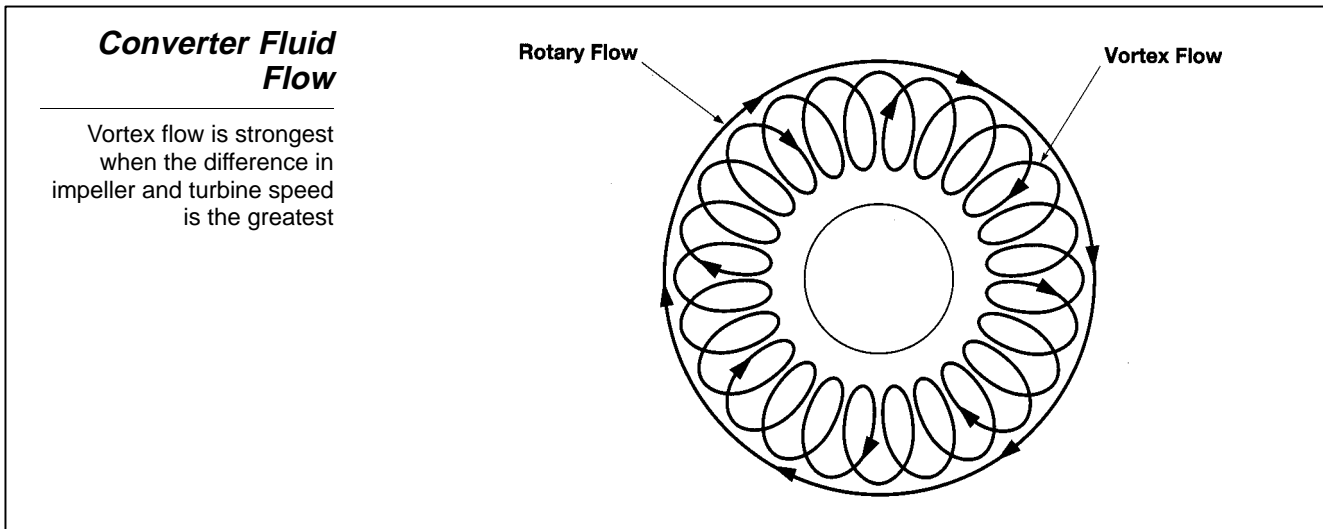

The flow is stronger when the difference in speed between the impeller and the turbine is great, as when the vehicle is accelerating for example. This is called high vortex. During this time the flow of fluid leaving the turbine strikes the front of the vanes of the stator and locks it on the stator reaction shaft, preventing it from rotating in the counterclockwise direction. The fluid passing through the stator is redirected by the shape of the vanes and strikes the back of the vanes of the impeller resulting in an increase in torque over that which is provided by the engine. Without the stator, the returning fluid would interfere with normal impeller rotation, reducing it severely.

Fluid Flow While Vehicle is Accelerating

Impeller turning much faster than turbine.

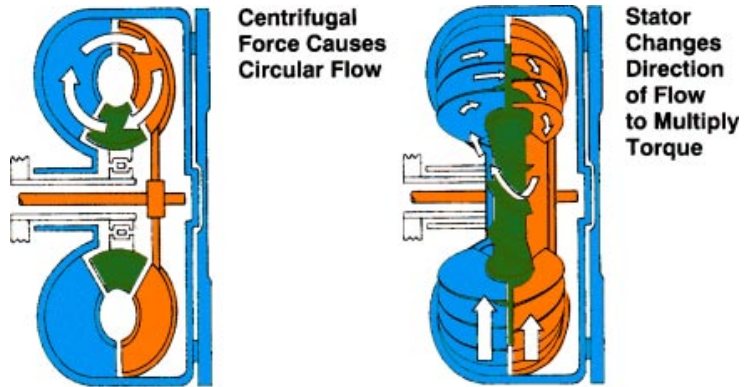

During times of low vortex flow the fluid coming from the turbine strikes the convex back of the vane rather than the concave face of the vane. This causes the one-way clutch to release and the stator freewheels on the reaction shaft. At this point there is little need for torque multiplication.

As the rotating speed of the impeller and the turbine become closer, the vortex flow decreases and the fluid begins to circulate with the impeller and turbine. This flow is referred to as rotary flow. Rotary flow is the flow of fluid inside the torque converter in the same direction as torque converter rotation. This flow is great when the difference in speed between the impeller and turbine is small, as when the vehicle is being driven at a constant speed. This is called the coupling point of the torque converter. At the coupling point, like the low vortex, the stator must freewheel in the clockwise direction. Should the stator fail to freewheel, it would impede the flow of fluid and tend to slow the vehicle.

Fluid Flow While Vehicle is Cruising

Impeller and Turbine at almost same speed

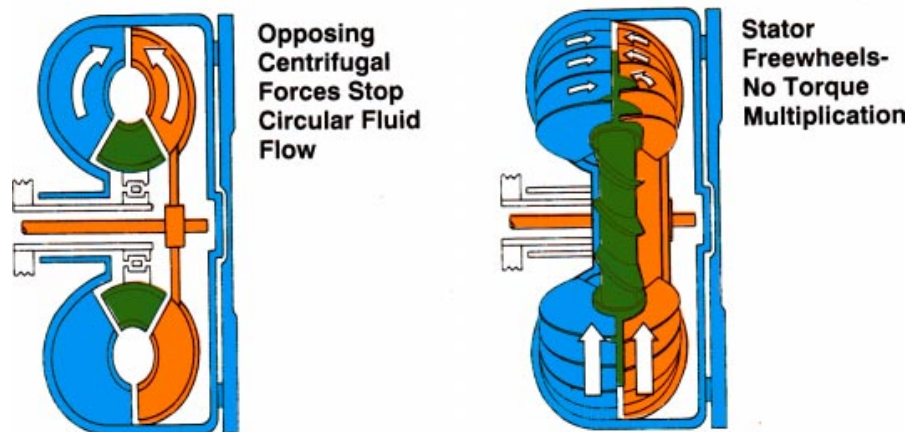

**Converter
Diagnosis**

Now that we understand the operation of the stator, let's examine what would happen if the stator was to malfunction. First, if the stator was to lock-up in both directions, at periods of high vortex the stator would function just perfectly. The fluid would be redirected, hit the back side of the impeller vanes and multiply torque and performance at low end would be just fine. But, as the impeller and turbine reach the coupling point, the fluid would hit the back of the stator vanes and disrupt the flow of fluid. This would hinder the flow of fluid and cause fluid to bounce off the vanes in a direction that would oppose the flow from the impeller to the turbine. This would cause the converter to work against itself and cause performance at top end to be poor. Continued operation at this coupling point would cause the fluid to overheat and can also affect the operating temperature of the engine.

A typical scenario might be that the customer operates the vehicle around town on surface streets and there is no indication of a problem. However when the vehicle is driven on the expressway for any appreciable distance, the engine overheats and does not have the top end performance it once had.

Second, if the stator was to free-wheel in both directions, the fluid from the turbine hitting the vanes of the stator would cause it to turn backwards and would not redirect the fluid and strike the impeller vanes in the opposite direction of engine rotation, in effect, reducing the torque converter to a fluid coupling with no benefit of torque multiplication. Performance on the lower end would be poor, acceleration would be sluggish. However, top end performance when the stator freewheels would be normal.

Service

The torque converter is a sealed unit and, as such, it is not serviceable. However, if contamination is found in the transmission then it will also be found in the torque converter. If the contamination in the converter is not dealt with, it will contaminate the overhauled transmission and cause a come-back. So for non-lock-up converters, flush the converter off the vehicle with specialized equipment. Flushing the converter with specialized equipment is not recommended for lock-up converters as it may deteriorate the clutch material. If contamination exists and it is a lock-up converter, replacement is required.

Torque Converter Testing

There are two ways to test a torque converter. The first method of testing is while it is in the vehicle; this is called a torque converter stall test. The second test method is while the converter is on the bench, and special tools are used to determine the condition of the stator one-way clutch.

Bench Testing

In order to bench test the converter, the stator one-way clutch must lock in one direction and freewheel in the other. Two special service tools are used to perform the test: the stator stopper and the one-way clutch test tool handle. Refer to the vehicle repair manual under the heading of "Torque Converter and Drive Plate" for the appropriate tool set because there are several different tool sets. The tool set number is listed before the tool number in the text of the repair manual.

Since the one-way clutch is subject to greater load while in the vehicle (while on the bench is only subject to the load you can place by hand), final determination is made when it is in the vehicle. You need to be familiar with the symptoms of the test drive, customer complaint and the condition of the holding devices in the transmission upon disassembly. All this information is important to determine the condition of the converter.

Bench Testing the Torque Converter

Place the converter on its side and use the stator stopper which locks the stator to the converter case while the test tool handle is turned clockwise and then counterclockwise.

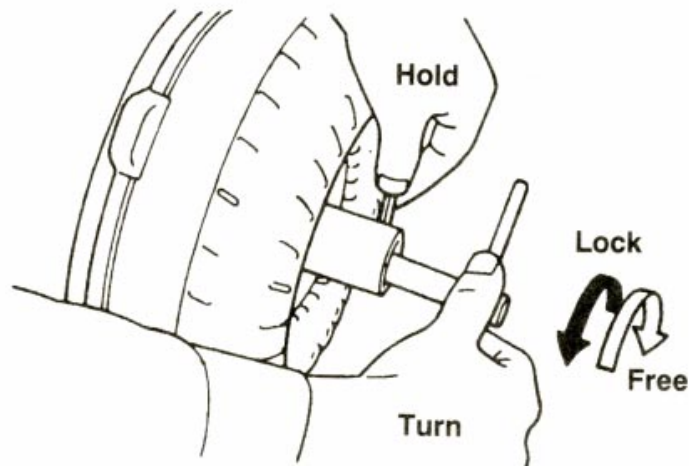

Stall Testing The term stall is the condition where the impeller moves but the turbine does not. The greatest amount of stall happens when the pump impeller is driven at the maximum speed possible without moving the turbine. The engine speed at which this occurs is called the torque converter stall speed.

Before stall testing a torque converter, consider the customer complaint and your test drive symptoms. The symptoms discussed previously regarding poor top end performance or poor acceleration may already point to the torque converter as the problem. A road test of the vehicle's acceleration and forced downshift will indicate a slipping stator if acceleration is poor. Poor top end performance will indicate a stator which does not freewheel.

When a stall test is performed and engine rpm falls within the specifications, it verifies several items:

- The one-way clutch in the torque converter stator is holding.
- Holding devices (clutches, brakes, and one-way clutches) used in first and reverse gears are holding properly.
- If the holding devices hold properly, the transmission oil pressure must be adequate.
- Engine is in a proper state of tune.

In preparing the vehicle for a stall test, the engine and transmission should both be at operating temperature and the ATF level should be at the proper level. Attach a tachometer to the engine. Place chocks at the front and rear wheels, set the hand brake and apply the foot brakes with your left foot. With the foot brakes fully applied, start the engine, place transmission in drive, and accelerate to wide open throttle and read the maximum engine rpm.

CAUTION

Do not stall test for a time period greater than five seconds as extreme heat is generated as the fluid is sheared in the torque converter. Allow at least one minute at idle speed for the fluid in the converter to cool.

Converter Installation

The torque converter installation to the drive plate is frequently overlooked and taken for granted. The concerns regarding installation are: vibration, oil sealing, and oil pump gear breakage. To ensure proper installation, measure the runout of drive plate and then the runout of the torque converter hub sleeve. Should runout exceed 0.0118" (0.30 mm) remove the converter and rotate its position until runout falls within specification. Mark the converter and drive plate position for installation when the transmission is installed. Should you be unable to obtain runout within the specification, replace the converter.

CAUTION

When replacing a converter or installing a remanufactured or dealer overhauled transmission, use only converter bolts to attach to flex plate. Similar bolts are too long and will dimple the converter clutch surface. See Transmission & Clutch TSB Numbers 016 and 036 of Volume 10.

The converter should be attached to the transmission first. Measure from the mounting lugs to the mating surface of the bell-housing. This ensures that the input shaft, stator reaction shaft, and the pump drive hub have all been properly seated. It also prevents any undue pressure on the front seal and hub sleeve while the transmission is maneuvered in place.

Lock-Up Clutch Mechanism

When the impeller and the turbine are rotating at nearly the same speed, no torque multiplication is taking place, the torque converter transmits the input torque from the engine to the transmission at a ratio of almost 1:1. There is however approximately 4% to 5% difference in rotational speed between the turbine and impeller. The torque converter is not transmitting 100% of the power generated by the engine to the transmission, so there is energy loss.

To prevent this, and to reduce fuel consumption, the lock-up clutch mechanically connects the impeller and the turbine when the vehicle speed is about 37 mph or higher. When the lock-up clutch is engaged, 100% of the power is transferred through the torque converter.

Converter Piston

To reduce fuel consumption, the converter piston engages the converter case to lock the impeller and the turbine

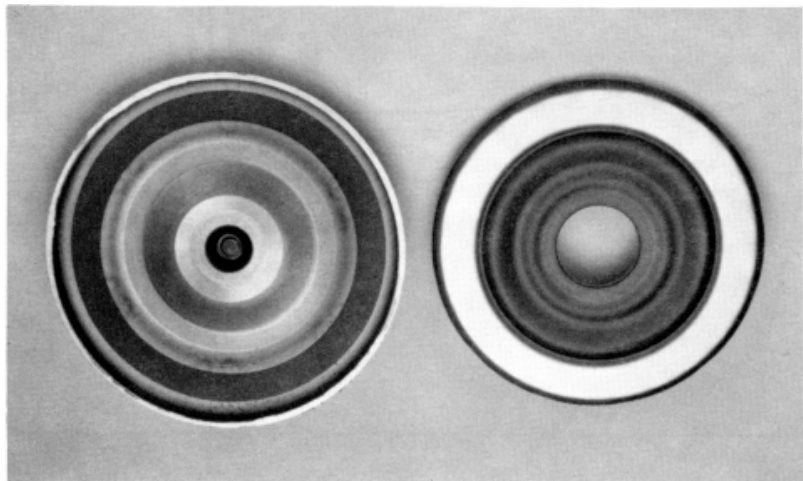

Construction The lock-up clutch is installed on the turbine hub, in front of the turbine. The dampening spring absorbs the torsional force upon clutch engagement to prevent shock transfer.

The friction material bonded to the lock-up piston is the same as that used on multiplate clutch disks in the transmission. When installing a new lockup converter be sure to fill it part way through the rear hub with approved automatic transmission fluid as it requires at least a 15-minute soak period prior to installation, similar to multiplate clutch discs.

Lock-up Operation When the lock-up clutch is actuated, it rotates together with the impeller and turbine. Engaging and disengaging of the lock-up clutch is determined by the point at which the fluid enters the torque converter. Fluid can either enter the converter in front of the lock-up clutch or in the main body of the converter behind the lock-up clutch. The difference in pressure on either side of the lock-up clutch determines engagement or disengagement.

The fluid used to control the torque converter lock-up is also used to remove heat from the converter and transfer it to the engine cooling system through the heat exchanger in the radiator.

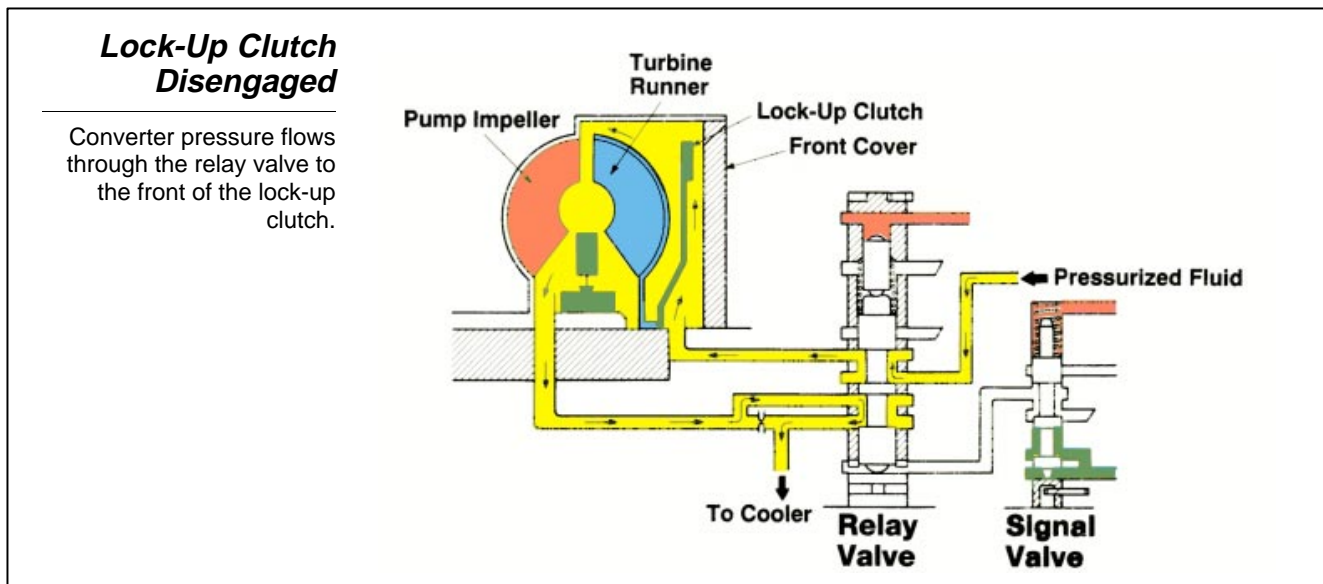

Valve Control Operation Control of the hydraulic fluid to the converter is accomplished by the relay valve and signal valve. Both valves are spring loaded to a position which leaves the clutch in a disengaged position. In the illustration above, converter pressure flows through the relay valve to the front of the lock-up clutch. Notice that the main body of the converter hydraulic circuit is connected to the transmission cooler through the bottom land of the relay valve.

The signal valve controls line pressure to the base of the relay valve. When governor pressure or line pressure is applied to the base of the signal valve, line pressure passes through the signal valve and is applied to the base of the relay valve. The relay valve moves up against spring tension diverting converter pressure to the main body of the converter.

Lock-Up Clutch Disengaged When the vehicle is running at low speeds (less than 37 mph) the pressurized fluid flows into the front of the lock-up clutch. The pressure on the front and rear sides of the lock-up clutch remains equal, so the lock-up clutch is disengaged.

Lock-Up Clutch Engaged When the vehicle is running at medium to high speeds (greater than 37 mph) the pressurized fluid flows into the area to the rear of the lock-up clutch. The relay valve position opens a drain to the area in front of the lock-up clutch, creating an area of low pressure. Therefore, the lock-up piston is forced against the converter case by the difference in hydraulic pressure on each side of the lock-up clutch. As a result, the lock-up clutch and the converter case rotate together.

Lock-Up Clutch Engaged

Converter pressure flows into the area to the rear of the lock-up clutch while a drain is open to the front of the clutch.

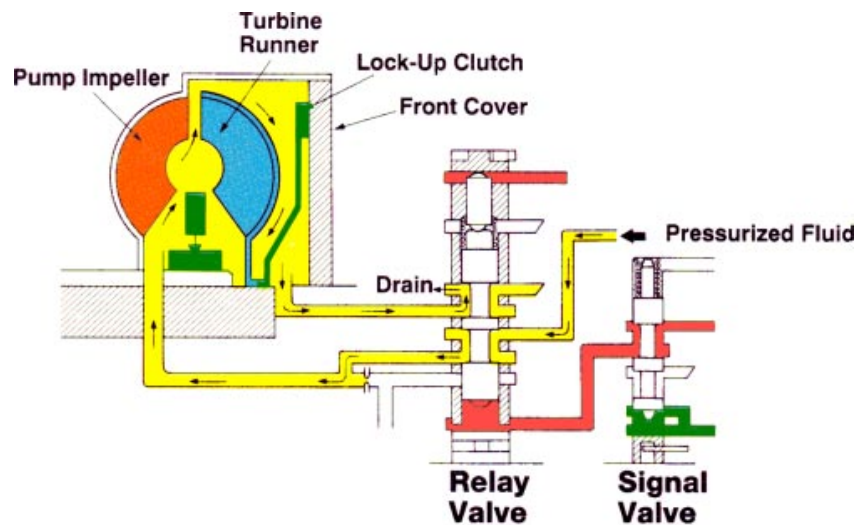



Notes